

# SAW FILTER

## Part Number: VTGG001

### Features

SAW filter for GPS and GLONASS.

- 1 High stability and reliability with good performance and no adjustment.
- 2 Narrow and sharp pass band characteristics. RoHS compatible.
- 3 Low insertion loss and deep stop band attenuation for interference.
- 4 Low – loss SAW filter.
- 5 Package size 1.4\*1.1

### Package Dimensions

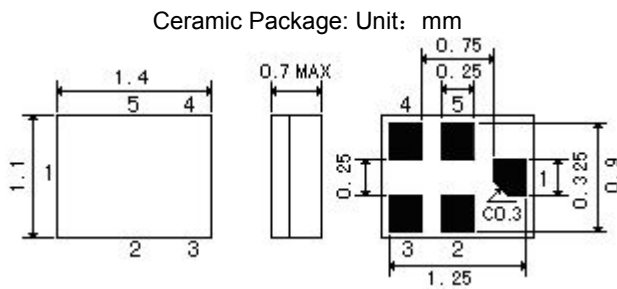

### Pin Configuration

1	Input
4	Output
2,3,5	Ground

### Marking

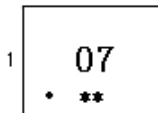

Top View, Laser Marking			
"07":	Part number	" 1":	Terminal 1
"* *":	Lot number (The code shown below varies in a 4-year cycle)		

Code	1	2	3	4	5	6	7	8	9	10	11	12
2015	a	b	c	d	e	f	g	h	i	j	k	m
2016	n	p	q	r	s	t	u	v	w	x	y	z
2017	A	B	C	D	E	F	G	H	J	K	L	M
2018	N	P	Q	R	S	T	U	V	W	X	Y	Z

### Maximum Ratings

Rating		Value	Unit
DC Voltage (between any Terminals)	$V_{DC}$	10	V
RF Power (in BW)	$P$	10	dBm
Operating Temperature Range	$T_A$	-40 ~ +85	°C
Storage Temperature Range	$T_{stg}$	-40 ~ +85	°C

**Electrical Characteristics:**

Item		Minimum	Typical	Maximum	Unit
Center Frequency	$f_c$	-	1588.655	-	MHz
Insertion Loss in 1573.42–1577.42MHz	IL	-	1.2	1.7	dB
Insertion Loss in 1571.42–1605.89MHz	IL	-	1.7	2.3	dB
Amplitude Variation in 1573.42–1577.42MHz			0.3	0.8	dB
Amplitude Variation in 1571.42–1605.89MHz			0.6	1.2	dB
Absolute Attenuation	$\alpha$				
0 ... 824.0MHz		43	48	-	dB
824.0 ... 849.0 MHz		48	53	-	dB
849.0 ... 880.0MHz		50	54	-	dB
880.0 ... 915.0 MHz		50	55	--	dB
915.0 ... 1452.0 MHz		31	36	--	dB
1452.0 ... 1538.655 MHz		23	27	--	dB
1638.655 ... 1710.0 MHz		25	30	--	dB
1710.0 ... 1785.0 MHz		32	37	--	dB
1785.0 ... 2170.0 MHz		30	34	--	dB
2170.0 ... 2690.0 MHz		25	29	--	dB
2690.0 ... 6000.0 MHz		20	25	--	dB
VSWR in 1573.42–1577.42MHz MHz		-	1.3	1.8	
VSWR in 1571.42–1605.89MHz		-	1.7	2.0	

**Pb** RoHS Compliant

**i** Electrostatic Sensitive Device

**Typical Frequency Response**

**S21**

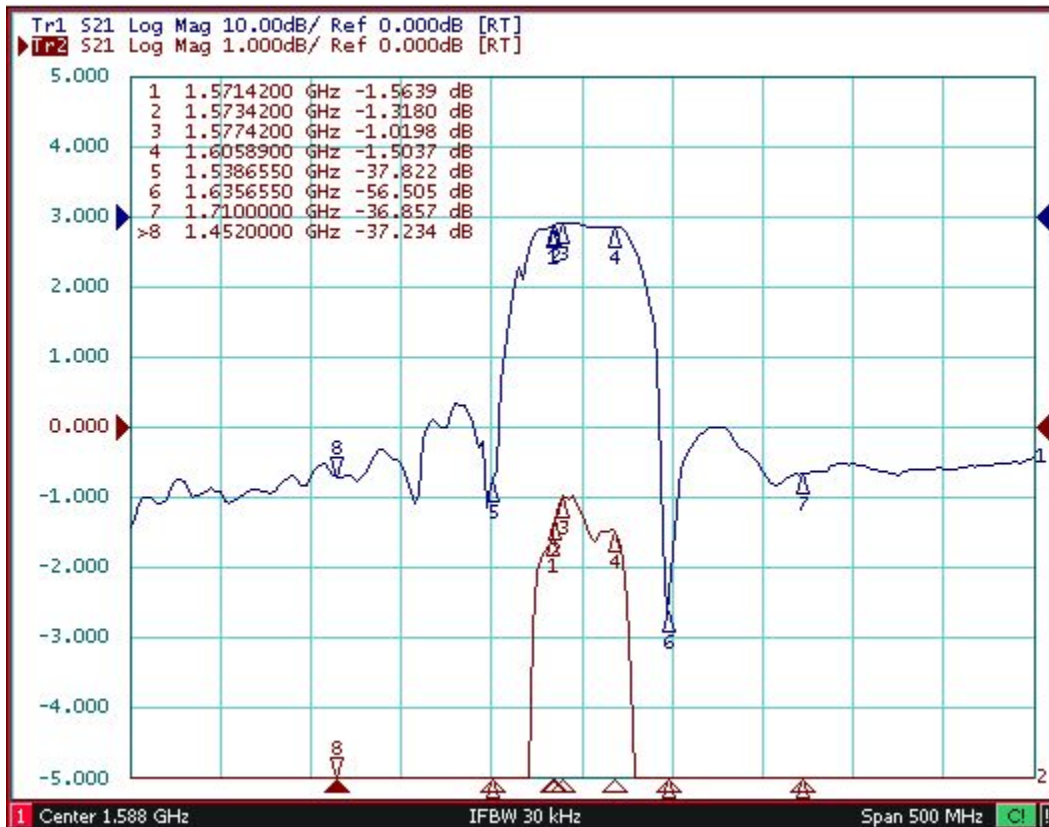

**VSWR and Group Delay**

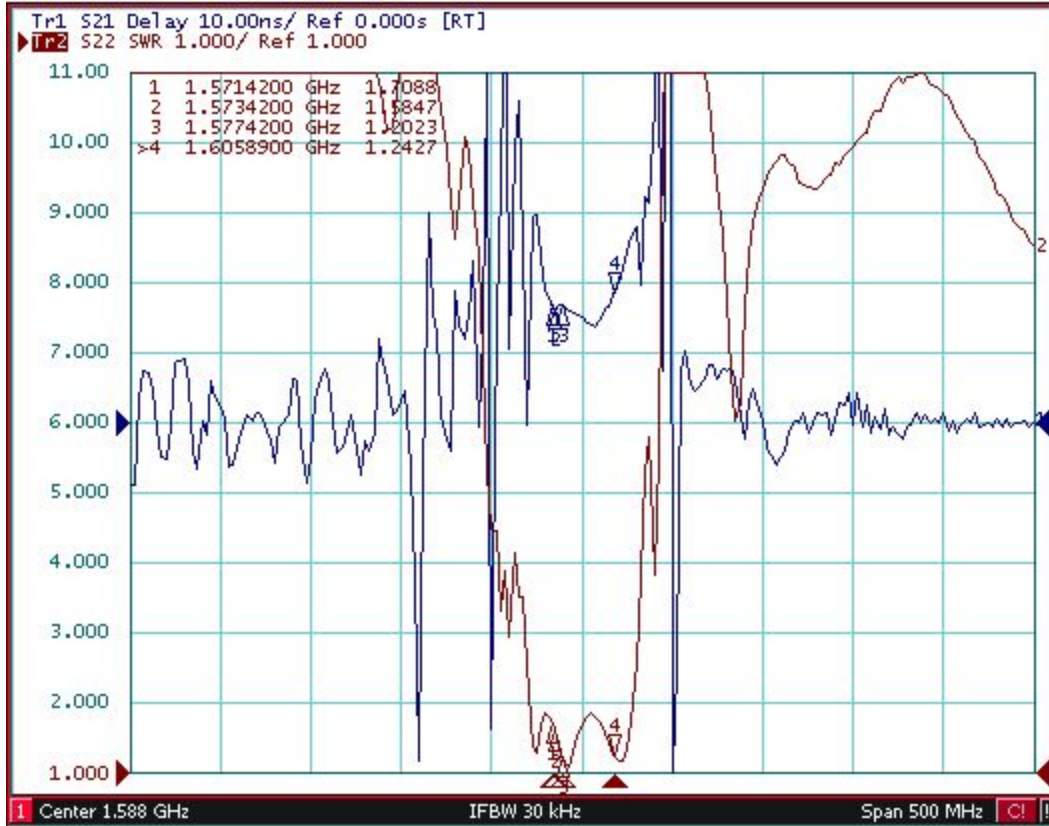

**Far Side**

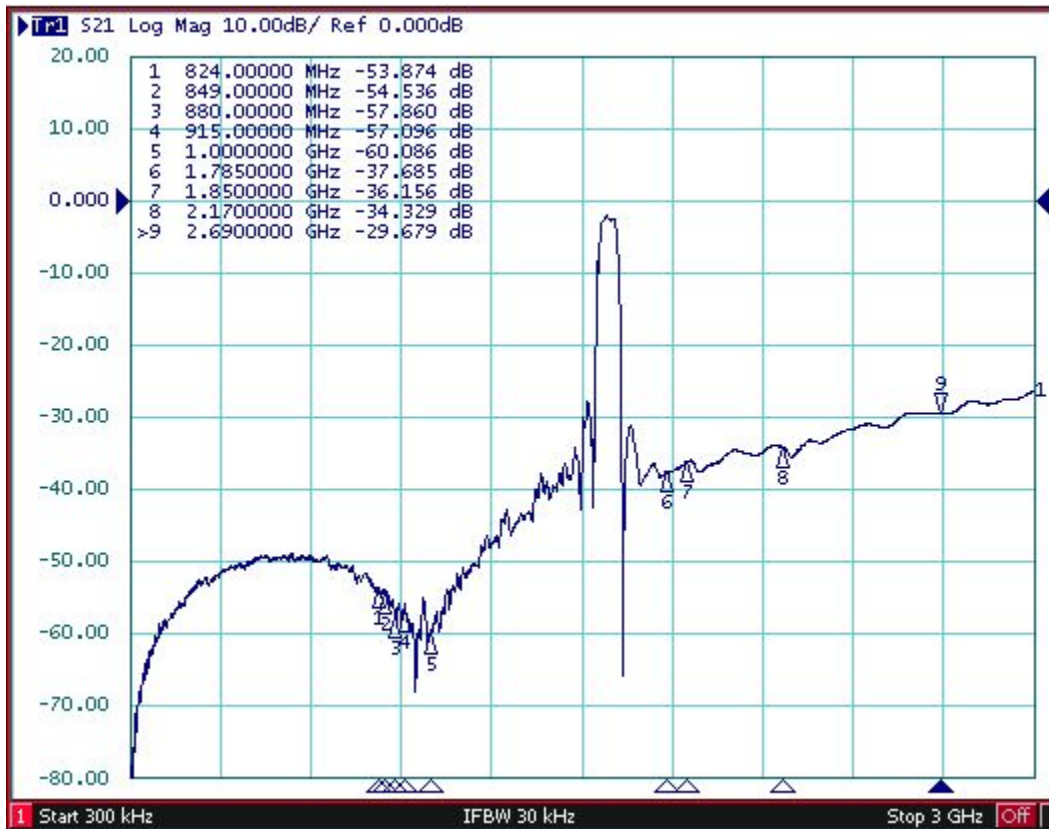

**Packing Information**

Carrier Tape

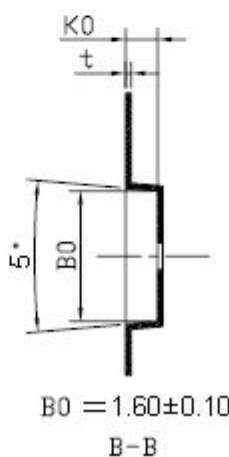
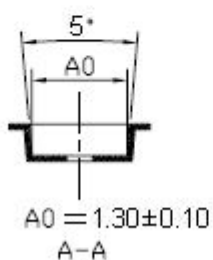
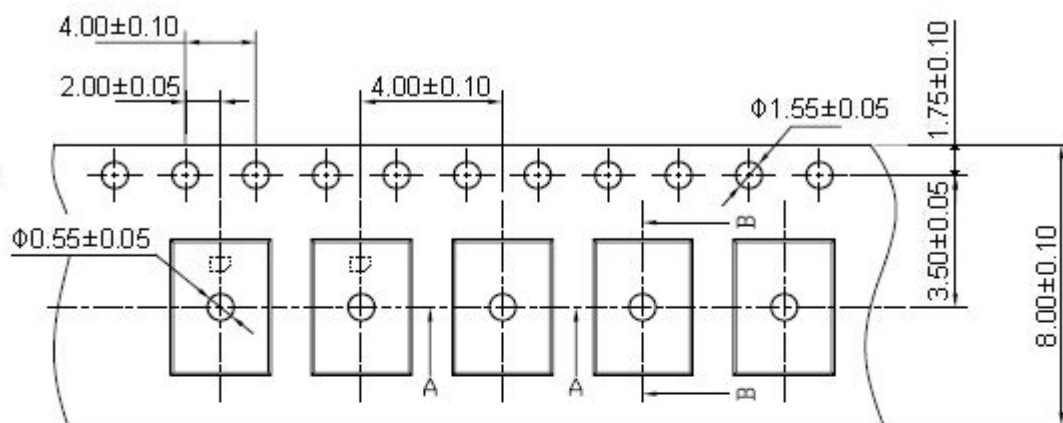

K0 = 0.90±0.10  
t = 0.20±0.05

Reel Dimensions

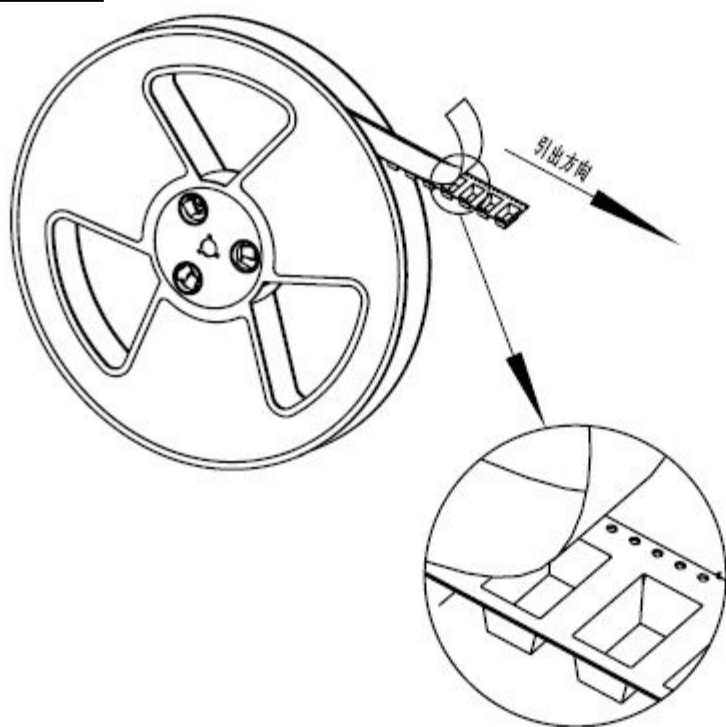

Material	PS
Unit	mm
Tolerance	±0.20 mm
Quantity	3000/reel

## Stability Characteristics

	Test item	Condition of test
1	Mechanical shock	(a) Drops: 3 times on concrete floor (b) Height: 1.0 m
2	Vibration resistance	(a) Frequency of vibration: 10~55Hz (c) Directions: X,Y and Z (b) Amplitude: 1.5 mm (d) Duration: 2 hours
3	Moisture resistance	(a) Condition: 40°C ± 2°C , 93+2 -3% RH. (b) Duration: 96 hours (c) Wait 4 hours before measurement
4	Climatic sequence	(a) +70°C for 16 hours (c) -25°C for 2 hours (e) Wait 4 hours before measurement (b) +55°C for 24 hours, 90~95% R.H. (d) +40°C for 24 hours, 90~95% R.H.
5	High temperature exposure	(a) Temperature: 85°C (c) Wait 4 hours before measurement (b) Duration: 250 hours
6	Temperature cycling	(a) +85°C for 30 minutes ⇒ -40°C for 30 minutes repeated 120 times (b) Wait 4 hours before measurement

**Requirements:** The SAW filter shall remain within the electrical specifications after tests.

### Remarks

- SAW devices should not be used in any type of fluid such as water, oil, organic solvent, etc.
- Be certain not to apply voltage exceeding the rated voltage of components.
- Do not operate outside the recommended operating temperature range of components.
- Sudden change of temperature shall be avoided, deterioration of the characteristics can occur.
- Be careful of soldering temperature and duration of components when soldering.
- Do not place soldering iron on the body of components.
- Be careful not to subject the terminals or leads of components to excessive force.
- SAW devices are electrostatic sensitive. Please avoid static voltage during operation and storage.
- Ultrasonic cleaning shall be avoided. Ultrasonic vibration may cause destruction of components.

### Test Circuit

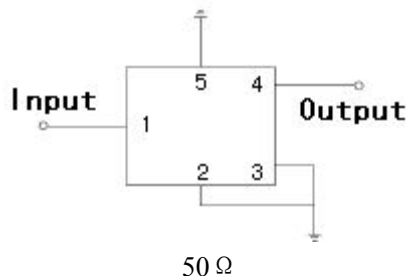

**Recommended Soldering Profile**

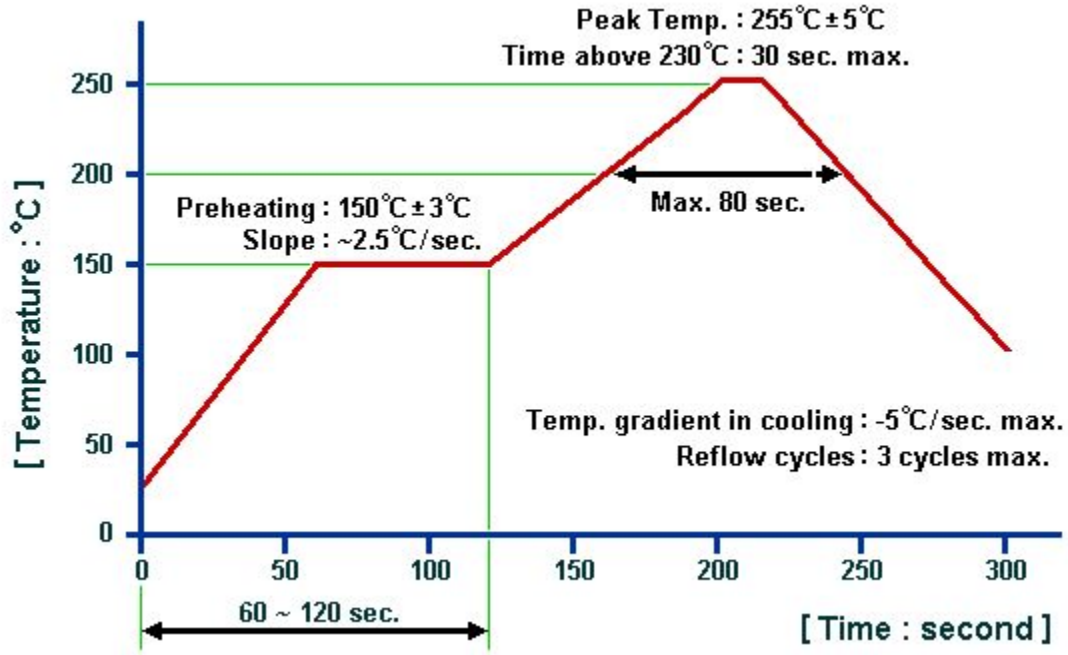

© V.TORCH 2015. All Rights Reserved.

1. The specifications of this device are subject to change or obsolescence without notice.
2. Typically, equipment utilizing this device requires emissions testing and government approval, which is the responsibility of the equipment manufacturer.
3. Our liability is only assumed for the Surface Acoustic Wave (SAW) component(s) per se, not for applications, processes and circuits implemented within components or assemblies.
4. For questions on technology, prices and delivery, please contact our sales offices or e-mail [info@v-torch.com](mailto:info@v-torch.com).