

SAW RESONATOR

Part Number: VTR7805B

The **VTR7805B** is a two-port, 180° surface-acoustic-wave (**SAW**) resonator in a surface-mount ceramic **QCC8C** case. It provides reliable, fundamental-mode, quartz frequency stabilization i.e. in transmitters or local oscillators operating at **780.000 MHz**.

1. Package Dimension (QCC8C)

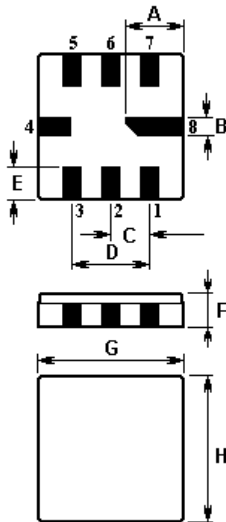

| Pin | Configuration |
|---------|---------------|
| 2 | Terminal1 |
| 6 | Terminal2 |
| 4,8 | Case Ground |
| 1,3,5,7 | Empty |

| Sign | Data (unit: mm) | Sign | Data (unit: mm) |
|------|-----------------|------|-----------------|
| A | 2.08 | E | 1.2 |
| B | 0.6 | F | 1.35 |
| C | 1.27 | G | 5.0 |
| D | 2.54 | H | 5.0 |

2. Marking

VTR
7805B

Laser Marking

3. Equivalent LC Model and Test Circuit

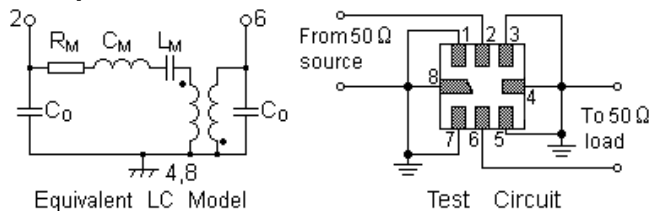

4. Typical Application Circuits

1) Low-Power Transmitter Application

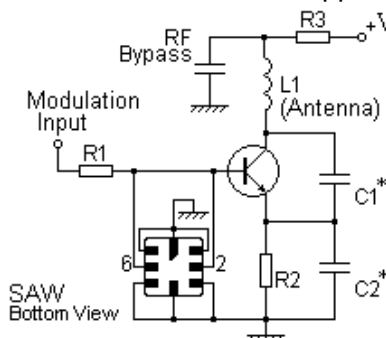

2) Local Oscillator Application

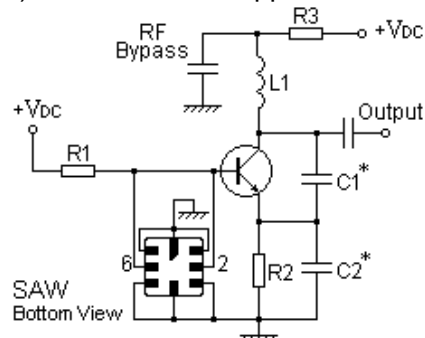

5. Typical Frequency Response

6. Temperature Characteristics

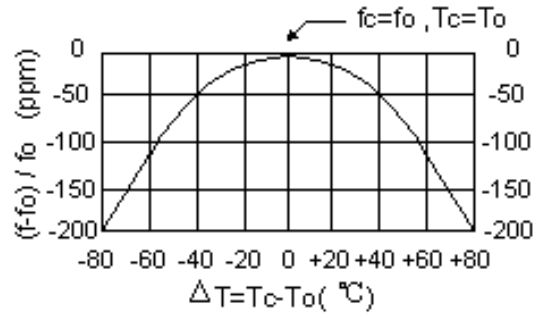
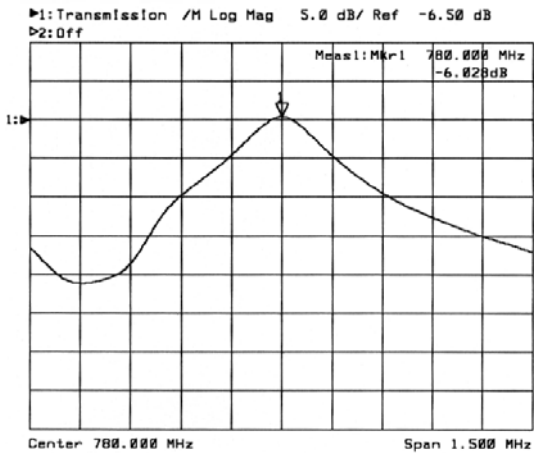

The curve shown above accounts for resonator contribution only and does not include LC component temperature characteristics.

7. Performance

7-1. Maximum Ratings

| Rating | Value | Unit |
|------------------------------|-----------|---------------|
| CW RF Power Dissipation | P | 10 dBm |
| DC Voltage Between Terminals | V_{DC} | ± 30 V |
| Storage Temperature Range | T_{stg} | -40 to +85 °C |
| Operating Temperature Range | T_A | -10 to +60 °C |

7-2. Electronic Characteristics

| Characteristics | | Sym | Minimum | Typical | Maximum | Unit |
|--|--------------------------------------|--------------|---------|-----------|---------|---------------------|
| Center Frequency (+25°C) | Absolute Frequency | f_c | 779.850 | | 780.150 | MHz |
| | Tolerance from 780.000 MHz | Δf_c | | ± 150 | | kHz |
| Insertion Loss | | IL | | 6.5 | 7.5 | dB |
| Quality Factor | Unloaded Q | Q_U | | 7,020 | | |
| | 50 Ω Loaded Q | Q_L | | 3,700 | | |
| Temperature Stability | Turnover Temperature | T_0 | 25 | | 55 | °C |
| | Turnover Frequency | f_0 | | f_c | | kHz |
| | Frequency Temperature Coefficient | FTC | | 0.032 | | ppm/°C ² |
| Frequency Aging | Absolute Value during the First Year | $ f_A $ | | ≤ 10 | | ppm/yr |
| DC Insulation Resistance Between Any Two Terminals | | | 1.0 | | | MΩ |
| RF Equivalent RLC Model | Motional Resistance | R_M | | 111.35 | 137 | Ω |
| | Motional Inductance | L_M | | 159.6429 | | μH |
| | Motional Capacitance | C_M | | 0.26106 | | fF |
| | Shunt Static Capacitance | C_0 | 1.2 | 1.5 | 1.8 | pF |

ⓘ CAUTION: Electrostatic Sensitive Device. Observe precautions for handling!

1. The frequency f_c is the frequency of minimum IL with the resonator in the specified test fixture in a 50 Ω test system with VSWR \leq 1.2:1.
2. Unless noted otherwise, case temperature $T_C = +25^\circ\text{C}\pm 2^\circ\text{C}$.
3. Frequency aging is the change in f_c with time and is specified at +65 $^\circ\text{C}$ or less. Aging may exceed the specification for prolonged temperatures above +65 $^\circ\text{C}$. Typically, aging is greatest the first year after manufacture, decreasing in subsequent years.
4. Turnover temperature, T_0 , is the temperature of maximum (or turnover) frequency, f_0 . The nominal frequency at any case temperature, T_C , may be calculated from: $f = f_0 [1 - \text{FTC} (T_0 - T_C)^2]$.
5. This equivalent RLC model approximates resonator performance near the resonant frequency and is provided for reference only. The capacitance C_0 is the measured static (nonmotional) capacitance between input terminal and ground or output terminal and ground. The measurement includes case parasitic capacitance.
6. Derived mathematically from one or more of the following directly measured parameters: f_c , IL, 3 dB bandwidth, f_c versus T_C , and C_0 .
7. The specifications of this device are based on the test circuit shown above and subject to change or obsolescence without notice.
8. Typically, equipment utilizing this device requires emissions testing and government approval, which is the responsibility of the equipment manufacturer.
9. Our liability is only assumed for the Surface Acoustic Wave (SAW) component(s) per se, not for applications, processes and circuits implemented within components or assemblies.
10. For questions on technology, prices and delivery, please contact our sales offices or e-mail info@v-torch.com