

WiFi Antenna

Part Number: VTWFA-5

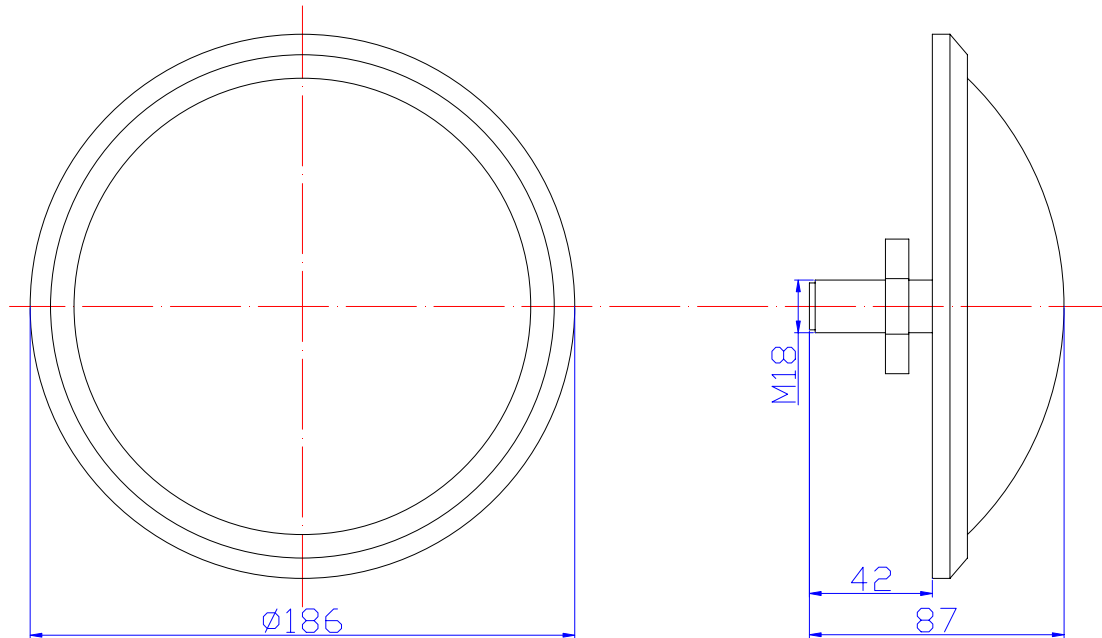

1 Dimension (Unit: mm)



2 Electrical Characteristics

2.1 GSM Antenna

Form 1

No.	Item	Specifications	Post Environmental
-----	------	----------------	--------------------

			Tolerance
1	Frequency (MHz)	2400~2500MHz	±3 MHz
2	V.S.W.R (in BW)	≤1.6 : 1	—
3	Gain (Zenith)	9dB	±0.5 dB
4	Polarization	Vertical	—
5	Impedance	50 Ω	—

2.2 Mechanical

Form 2

No.	Item	Specification
1	Cable	—
2	Connector	MCX
3	Plastic Housing	Black
4	Size	Φ9×110mm

3 Reliability

Condition: Temperature: 40±5℃

Load: DC=5V±0.5 V

Quantity: 2000pcs

Sustained Time: 480h

4 Environmental Specifications

Condition:

Post Environmental Tolerance (Refer to the form 1)

Temperature range 25±3℃

Relative Humidity range 55~75%RH

Operating Temperature range -40℃~+85℃

Storage Temperature range -40℃~+100℃

5.1 Moisture Proof

The device should satisfy the electrical characteristics specified in form 1 after exposed to the temperature 40±2℃ and the relative humidity 90~95% RH for 96 hours and 1~2 hours recovery time under normal condition.

5.2 Vibration Resist

The device should satisfy the electrical characteristics specified in form 1 after applied to the vibration of 10 to 55Hz with amplitude of 1.5mm for 2 hours each in X , Y and Z directions.

5.3 Drop Shock

The device should satisfy the electrical characteristics specified in form 1 after dropping onto the hard wooden board from the height of 30cm for 3 times each facet of the 3 dimensions of the device.

5.4 High Temperature Endurance

The device should satisfy the electrical characteristics specified in form 1 after exposed to temperature 80±5℃ for 24±2 hours and 1~2 hours recovery time under normal temperature.

5.5 Low Temperature Endurance

The device should also satisfy the electrical characteristics specified in form 1 after exposed to the temperature -40℃±5℃ for 24±2 hours and to 2 hours recovery time under normal temperature.

5.6 Temperature Cycle Test

The device should also satisfy the electrical characteristics specified in form 1 after exposed to the low temperature -25°C and high temperature $+85^{\circ}\text{C}$ for 30 ± 2 min each by 5 cycles and 1 to 2 hours recovery time under normal temperature.